

Connecting Kids to Nature

Nature is a great teacher! Try this outdoor activity - it's safe, fun, and educational. Use Project Learning Tree® activities to get children outside and teach them about what the environment needs to remain healthy and sustainable. Visit plt.org/store for more.



Project Learning Tree® (PLT) is a program of the American Forest Foundation.

Activity 63: Tree Factory

By acting out the parts of a tree, children will learn about tree structure and function. Engage children by asking them to think about what trees need to survive (food, sun, water, air, and space). Discuss how a tree might get these requirements, especially since they can't move around the way animals can.

- How does a tree get the water it needs?
- How does a tree get the food it needs?
- How does water and food get around to all parts of the tree?

Explain that in addition to having leaves and roots, trees have special layers in their trunk and branches that help them move nutrients and water to every part of the tree. The trunk and branches also contain a growing layer of cells that create the tree's annual growth rings, making the trunk, branches, and roots thicker each year. Review the following tree parts and have children label the diagram.

- (a) **Heartwood** - forms the central core of the tree. It is made up of dense dead wood, and it provides strength.
- (b) **Xylem** - brings water and nutrients up from the roots to the leaves. Older xylem cells become part of the heartwood.
- (c) **Cambium** - a very thin layer of growing tree tissue. It makes cells that become new xylem, phloem, or cambium.
- (d) **Phloem** - carries sap from the leaves to the rest of the tree. At certain times of the year, phloem may also move stored sugars from the roots up to the rest of the tree.
- (e) **Outer Bark** - protects the tree from injury caused by insects, animals, plants, diseases, and fire.

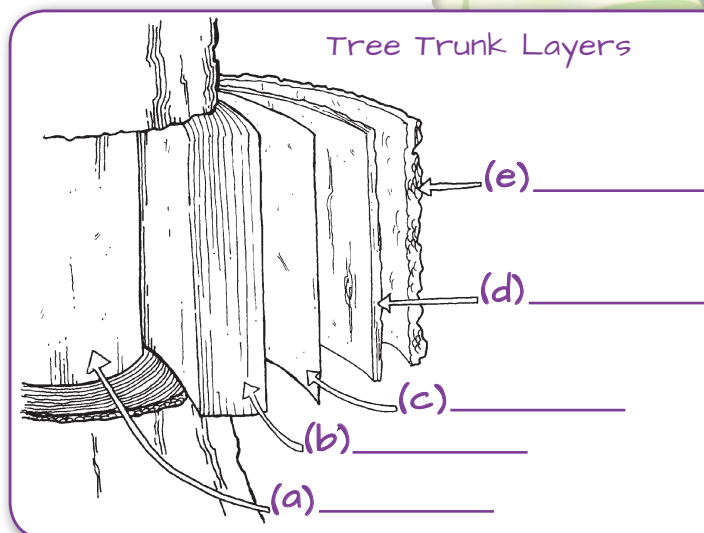

Build a Tree Factory

Using the chart below, have children build a "Tree Factory" by coming up with their own actions and chants to represent the structure and function of the tree parts reviewed above. The chart has been started to help you. Hint: The chant helps to determine the function!

STRUCTURE	FUNCTION	CHANT	ACTION
Roots	Anchor the tree, absorb water and nutrients	"We anchor!"	Lay down and hold onto the ground tight
Leaves	Make food through photosynthesis	"We make food!"	Flutter your hands
Heartwood		"I support!"	Flex your muscles
Xylem		"I pump!"	
Cambium		"I make new cells!"	
Phloem		"I carry sap!"	
Outer Bark		"I protect!"	Hold up hands or cross arms to make a shield

To reinforce learning and fire up this Tree Factory, have children shout the chant and perform the action chosen for each tree part.

PLT improves children's environmental awareness, critical thinking skills, and academic performance.

- Attend a workshop near you to receive PreK-12 PLT activities, ideas, and materials.
- Encourage your child's school to incorporate outdoor learning and PLT.
- Learn more at www.plt.org or call 202-765-3641

©American Forest Foundation. Adapted from Activity 63: Tree Factory from Project Learning Tree's PreK-8 Environmental Education Activity Guide.

www.plt.org